

Seal Gas Filters Special Gas Filters

- Non Welded Design
- API 614 5th edition / API 692
- ASME VIII div.1
- Single, Duplex & Double Block & Bleed configuration
- All exotic material available
- Zero Leak Transfer Valve
- All connections are available
- Integrated Equalizing Line
- Available from 1/2" full bore

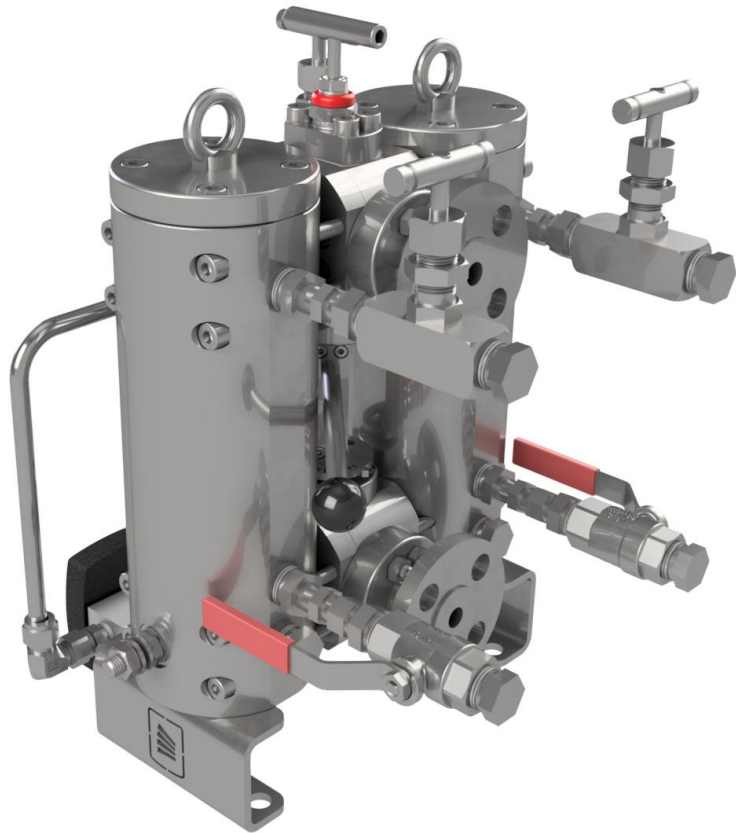

Lube Oil Filters Special Liquid Filters

- Non Welded Design
- API 614 5th edition
- ASME VIII div.1
- Single, Duplex configuration
- All exotic material available
- Zero Leak Transfer Valve
- All connections are available
- Integrated Equalizing Line
- Available from 1/2" full bore

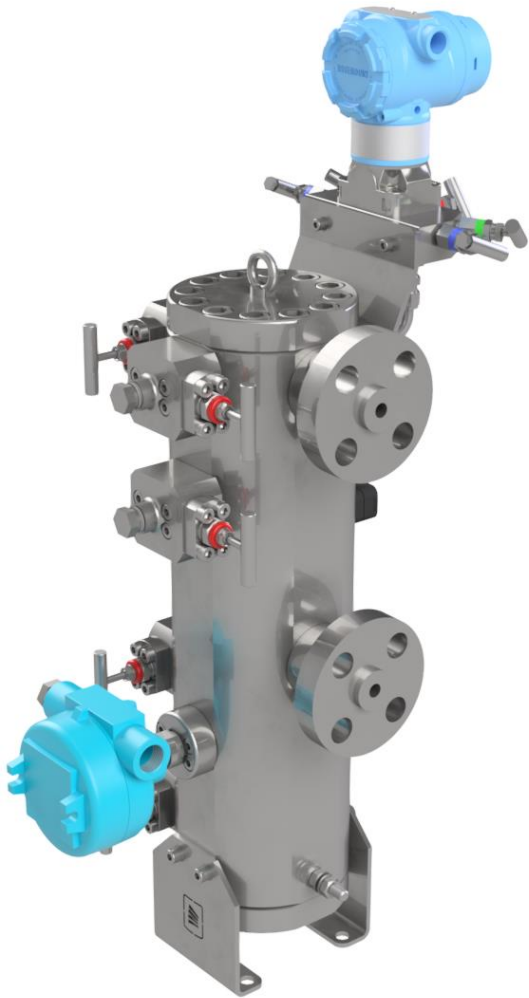

Fuel gas Filters

- Non Welded Design
- Custom Options
- ASME VIII div.1
- Single, Duplex configuration
- All exotic material available
- Multiple stages
- All connections are available
- Available from 1/2" full bore

TM Chemical Injection / TM High Pressure Hydraulic Filters



Hydraulic Filters Chemical Injection Filters

- Non Welded Design
- High Pressure > 1000 bar
- High Temperature > 350°C
- All exotic material available
- Filtration Efficiencies ranging from: 500µm to 0,2µm
- Special seals for hazardous application

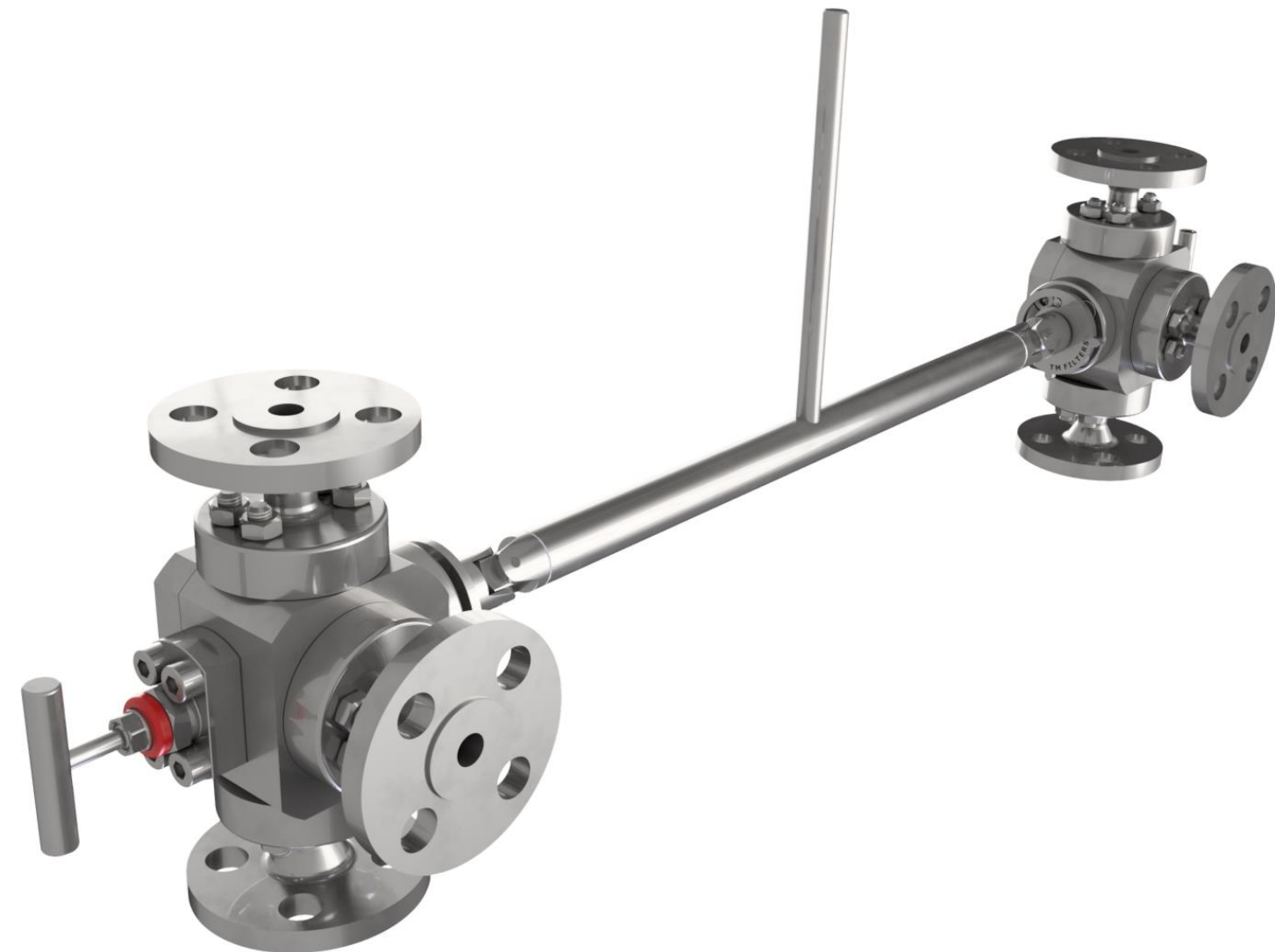

TM Double 3-Way Valve

- Non Welded Design
- Zero Leak
- 1 Lever switch over
- Custom Made
- Integrated equalizing line
- Exotic material available
- Any connection available

Summary

Designing, Machining and
Manufacturing under one roof

Maximum Customer Service

Non Welded Design

Comply to all International Standards, OEM, EPC &
End User Specifications

Safety First

ASME VIII Division 1

API 614 latest edition

Wide range of filter product line

Custom Made Solutions Fit & Function

Exotic Materials

